

ISSN 2518-170X (Online)

ISSN 2224-5278 (Print)

**NEWS OF THE NATIONAL ACADEMY
OF SCIENCES OF THE REPUBLIC
OF KAZAKHSTAN, SERIES OF
GEOLOGY AND TECHNICAL SCIENCES**

№2

2026

ISSN 2518-170X (Online)

ISSN 2224-5278 (Print)



N E W S
OF THE NATIONAL ACADEMY OF SCIENCES
OF THE REPUBLIC OF KAZAKHSTAN,
SERIES OF GEOLOGY AND TECHNICAL
SCIENCES

2 (476)
MARCH – APRIL 2026

THE JOURNAL WAS FOUNDED IN 1940

PUBLISHED 6 TIMES A YEAR

ALMATY, 2026

The scientific journal News of the National Academy of Sciences of the Republic of Kazakhstan, Series of Geology and Technical Sciences has been indexed in the international abstract and citation database Scopus since 2016 and demonstrates stable bibliometric performance.

The journal is also included in the Emerging Sources Citation Index (ESCI) of the Web of Science platform (Clarivate Analytics, since 2018).

Indexing in ESCI confirms the journal's compliance with international standards of scientific peer review and editorial ethics and is considered by Clarivate Analytics as part of the evaluation process for potential inclusion in the Science Citation Index Expanded (SCIE), Social Sciences Citation Index (SSCI), and Arts & Humanities Citation Index (AHCI).

Indexing in Scopus and Web of Science ensures high international visibility of publications, promotes citation growth, and reflects the editorial board's commitment to publishing relevant, original, and scientifically significant research in the fields of geology and technical sciences.

«Қазақстан Республикасы Ұлттық ғылым академиясының Хабарлары. Геология және техникалық ғылымдар сериясы» ғылыми журналы 2016 жылдан бастап халықаралық реферативтік және ғылымиметриялық Scopus дерекқорында индекстеледі және тұрақты библиометриялық көрсеткіштерді көрсетіп келеді.

Сонымен қатар журнал Web of Science платформасының (Clarivate Analytics, 2018) халықаралық реферативтік және наукометриялық дерекқоры Emerging Sources Citation Index (ESCI) тізіміне енгізілген.

ESCI дерекқорында индекстелуі журналдың халықаралық ғылыми рецензиялау талаптары мен редакциялық этика стандарттарына сәйкестігін растайды, сондай-ақ Clarivate Analytics компаниясы тарапынан басылмды Science Citation Index Expanded (SCIE), Social Sciences Citation Index (SSCI) және Arts & Humanities Citation Index (AHCI) дерекқорларына енгізу қарастырылуда.

Scopus және Web of Science дерекқорларында индекстелуі жарияланымдардың халықаралық деңгейде жоғары сұранысқа ие болуын қамтамасыз етеді, олардың дәйексөз алу көрсеткіштерінің артуына ықпал етеді және редакциялық алқаның геология мен техникалық ғылымдар саласындағы өзекті, бірегей және ғылыми тұрғыдан маңызды зерттеулерді жариялауға ұмтылысын айқындайды.

Научный журнал «News of the National Academy of Sciences of the Republic of Kazakhstan, Series of Geology and Technical Sciences» с 2016 года индексируется в международной реферативной и наукометрической базе данных Scopus и демонстрирует стабильные библиометрические показатели.

Журнал также включён в международную реферативную и наукометрическую базу данных Emerging Sources Citation Index (ESCI) платформы Web of Science (Clarivate Analytics, 2018).

Индексирование в ESCI подтверждает соответствие журнала международным стандартам научного рецензирования и редакционной этики, а также рассматривается компанией Clarivate Analytics в рамках дальнейшего включения издания в Science Citation Index Expanded (SCIE), Social Sciences Citation Index (SSCI) и Arts & Humanities Citation Index (AHCI).

Индексирование в Scopus и Web of Science обеспечивает высокую международную востребованность публикаций, способствует росту цитируемости и подтверждает стремление редакционной коллегии публиковать актуальные, оригинальные и научно значимые исследования в области геологии и технических наук.

EDITOR-IN-CHIEF

ZHURINOV Murat Zhurinovich, Doctor of Chemical Sciences, Professor, Academician of IAAS and NAS RK, General Director of the Research Institute of Petroleum Refining and Petrochemicals (Almaty, Kazakhstan), <https://www.scopus.com/authid/detail.uri?authorId=6602177960>; <https://www.webofscience.com/wos/author/record/2017489>

DEPUTY EDITOR-IN-CHIEF

ABSADYKOV Bakhyt Narikbayevich, Doctor of Technical Sciences, Professor, Academician of NAS RK, Satbayev University (Almaty, Kazakhstan), <https://www.scopus.com/authid/detail.uri?authorId=6504694468>; <https://www.webofscience.com/wos/author/record/2411827>

EDITORIAL BOARD:

ABSAMETOV Malis Kudysovich, Doctor of Geological and Mineralogical Sciences, Professor, Academician of NAS RK, Director of the U.M. Akhmedsafin Institute of Hydrogeology and Geocology (Almaty, Kazakhstan), <https://www.scopus.com/authid/detail.uri?authorId=56955769200>; <https://www.webofscience.com/wos/author/record/1937883>

ZHOLTAEV Geroy Zholtaevich, Doctor of Geological and Mineralogical Sciences, Professor, Honorary Academician of NAS RK (Almaty, Kazakhstan), <https://www.scopus.com/authid/detail.uri?authorId=57112610200>; <https://www.webofscience.com/wos/author/record/1939201>

SNOW Daniel, PhD, Associate Professor, Director, Aquatic Sciences Laboratory, University of Nebraska (Nebraska, USA), <https://www.scopus.com/authid/detail.uri?authorId=7103259215>; <https://www.webofscience.com/wos/author/record/1429613>

SELTMANN Reimar, PhD, Head of Petrology and Mineral Deposits Research in the Earth Sciences Department, Natural History Museum (London, Great Britain), <https://www.scopus.com/authid/detail.uri?authorId=55883084800>; <https://www.webofscience.com/wos/author/record/1048681>

PANFILOV Mikhail Borisovich, Doctor of Technical Sciences, Professor at the University of Nancy (Nancy, France), <https://www.scopus.com/authid/detail.uri?authorId=7003436752>; <https://www.webofscience.com/wos/author/record/1230499>

SHEN Ping, PhD, Deputy Director of the Mining Geology Committee of the Chinese Geological Society, Member of the American Association of Economic Geologists (Beijing, China), <https://www.scopus.com/authid/detail.uri?authorId=57202873965>; <https://www.webofscience.com/wos/author/record/1753209>

FISCHER Axel, PhD, Associate Professor, Technical University of Dresden (Dresden, Germany), <https://www.scopus.com/authid/detail.uri?authorId=35738572100>; <https://www.webofscience.com/wos/author/record/2085986>

AGABEKOV Vladimir Enokovich, Doctor of Chemical Sciences, Academician of NAS of Belarus, Honorary Director of the Institute of Chemistry of New Materials (Minsk, Belarus), <https://www.scopus.com/authid/detail.uri?authorId=7004624845>

CATALIN Stefan, PhD, Associate Professor, Technical University of Dresden (Dresden, Germany), <https://www.scopus.com/authid/detail.uri?authorId=35203904500>; <https://www.webofscience.com/wos/author/record/1309251>

JAY Sagin, PhD, Associate Professor, Nazarbayev University (Astana, Kazakhstan), <https://www.scopus.com/authid/detail.uri?authorId=57204467637>; <https://www.webofscience.com/wos/author/record/907886>

FRATTINI Paolo, PhD, Associate Professor, University of Milano - Bicocca (Milan, Italy), <https://www.scopus.com/authid/detail.uri?authorId=56538922400>

NURPEISOVA Marzhan Baysanovna, Doctor of Technical Sciences, Professor of Satbayev University (Almaty, Kazakhstan), <https://www.scopus.com/authid/detail.uri?authorId=57202218883>; <https://www.webofscience.com/wos/author/record/AAD-1173-2019>

RATOV Boranbay Tovbasarovich, Doctor of Technical Sciences, Professor, Head of the Department of Geophysics and Seismology, Satbayev University (Almaty, Kazakhstan), <https://www.scopus.com/authid/detail.uri?authorId=55927684100>; <https://www.webofscience.com/wos/author/record/1993614>

RONNY Berndtsson, Professor, Director of the Centre for Advanced Middle Eastern Studies, Lund University (Lund, Sweden), <https://www.scopus.com/authid/detail.uri?authorId=7005388716>; <https://www.webofscience.com/wos/author/record/1324908>

MIRLAS Vladimir, PhD, Professor, Eastern R&D Center, Ariel University (Ariel, Israel), <https://www.scopus.com/authid/detail.uri?authorId=8610969300>; <https://www.webofscience.com/wos/author/record/53680261>

News of the National Academy of Sciences of the Republic of Kazakhstan. Series of geology and technology sciences.

ISSN 2518-170X (Online),

ISSN 2224-5278 (Print)

Owner: «Central Asian Academic Research Center» LLP (Almaty).

The certificate of registration of a periodical printed publication in the Committee of information of the Ministry of Information and Communications of the Republic of Kazakhstan № KZ50VPY00121155, issued on 05.06.2025
Thematic scope: *geology, hydrogeology, geography, mining and chemical technologies of oil, gas and metals*
Periodicity: 6 times a year.

<http://www.geology-technical.kz/index.php/en/>

© «Central Asian Academic Research Center» LLP, 2026.

БАС РЕДАКТОР

ЖУРЫНОВ Мұрат Жұрынулы, химия ғылымдарының докторы, профессор, ХҒАҚ және ҚР ҰҒА академигі, Мұнай өңдеу және мұнай-химиясы ғылыми-зерттеу институтының бас директоры (Алматы, Қазақстан), <https://www.scopus.com/authid/detail.uri?authorId=6602177960>; <https://www.webofscience.com/wos/author/record/2017489>

БАС РЕДАКТОРДЫҢ ОРЫНБАСАРЫ:

АБСАДЫҚОВ Бақыт Нәрікбайұлы, техника ғылымдарының докторы, профессор, ҚР ҰҒА академигі, Қ.И. Сәтбаев атындағы Қазақ ұлттық техникалық зерттеу университеті (Алматы, Қазақстан), <https://www.scopus.com/authid/detail.uri?authorId=6504694468>; <https://www.webofscience.com/wos/author/record/2411827>

РЕДАКЦИЯ АЛҚАСЫ:

ӘБСӘМЕТОВ Мәліс Құдысұлы, геология-минералогия ғылымдарының докторы, профессор, ҚР ҰҒА академигі, У.М. Ахмедсафин атындағы Гидрогеология және геоэкология институтының директоры (Алматы, Қазақстан), <https://www.scopus.com/authid/detail.uri?authorId=56955769200>; <https://www.webofscience.com/wos/author/record/1937883>

ЖОЛТАЕВ Герой Жолтайұлы, геология-минералогия ғылымдарының докторы, профессор, ҚР ҰҒА құрметті академигі (Алматы, Қазақстан), <https://www.scopus.com/authid/detail.uri?authorId=57112610200>; <https://www.webofscience.com/wos/author/record/1939201>

СНОУ Дэниел, PhD, қауымдастырылған профессор, Небраска университетінің Су ғылымдары зертханасының директоры (Небраска, АҚШ), <https://www.scopus.com/authid/detail.uri?authorId=7103259215>; <https://www.webofscience.com/wos/author/record/1429613>

ЗЕЛЪТМАНН Раймар, PhD, Жер туралы ғылымдар бөлімінің петрология және пайдалы қазбалар кен орындары саласындағы зерттеулерінің жетекшісі, Табиғи тарих мұражайы (Лондон, Ұлыбритания), <https://www.scopus.com/authid/detail.uri?authorId=55883084800>; <https://www.webofscience.com/wos/author/record/1048681>

ПАНФИЛОВ Михаил Борисович, техника ғылымдарының докторы, Нанси университетінің профессоры (Нанси, Франция), <https://www.scopus.com/authid/detail.uri?authorId=7003436752>; <https://www.webofscience.com/wos/author/record/1230499>

ШЕН Пин, PhD, Қытай геологиялық қоғамының Тау-кен геологиясы комитеті директорының орынбасары, Американдық экономикалық геологтар қауымдастығының мүшесі (Бейжің, Қытай), <https://www.scopus.com/authid/detail.uri?authorId=57202873965>; <https://www.webofscience.com/wos/author/record/1753209>

ФИШЕР Аксель, PhD, қауымдастырылған профессор, Дрезден техникалық университеті (Дрезден, Германия), <https://www.scopus.com/authid/detail.uri?authorId=35738572100>; <https://www.webofscience.com/wos/author/record/2085986>

АГАБЕКОВ Владимир Енокович, химия ғылымдарының докторы, Беларусь ҰҒА академигі, Жаңа материалдар химиясы институтының құрметті директоры (Минск, Беларусь), <https://www.scopus.com/authid/detail.uri?authorId=7004624845>

КАТАЛИН Стефан, PhD, қауымдастырылған профессор, Дрезден Техникалық университеті (Дрезден, Германия), <https://www.scopus.com/authid/detail.uri?authorId=35203904500>; <https://www.webofscience.com/wos/author/record/1309251>

САҒЫНТАЕВ Жанай, PhD, қауымдастырылған профессор, Назарбаев университеті (Астана, Қазақстан), <https://www.scopus.com/authid/detail.uri?authorId=57204467637>; <https://www.webofscience.com/wos/author/record/907886>

ФРАТТИНИ Паоло, PhD, қауымдастырылған профессор, Бикокок Милан университеті (Милан, Италия), <https://www.scopus.com/authid/detail.uri?authorId=56538922400>

НҮРПЕЙСОВА Маржан Байсанқызы, техника ғылымдарының докторы, Қ.И. Сәтбаев атындағы Қазақ ұлттық техникалық зерттеу университетінің профессоры (Алматы, Қазақстан), <https://www.scopus.com/authid/detail.uri?authorId=57202218883>; <https://www.webofscience.com/wos/author/record/AAD-1173-2019>

РАТОВ Боранбай Товбасарович, техника ғылымдарының докторы, профессор, «Геофизика және сейсмология» кафедрасының меңгерушісі, Қ.И. Сәтбаев атындағы Қазақ ұлттық техникалық зерттеу университеті (Алматы, Қазақстан), <https://www.scopus.com/authid/detail.uri?authorId=55927684100>; <https://www.webofscience.com/wos/author/record/1993614>

РОННИ Бердтссон, профессор, Таяу Шығысты заманауи зерттеу орталығының директоры, Лунд университеті (Лунд, Швеция), <https://www.scopus.com/authid/detail.uri?authorId=7005388716>; <https://www.webofscience.com/wos/author/record/1324908>

МИРІАС Владимир, PhD, профессор, Ариэль университетінің Шығыс ғылыми-зерттеу орталығы (Ариэль, Израиль), <https://www.scopus.com/authid/detail.uri?authorId=8610969300>; <https://www.webofscience.com/wos/author/record/53680261>

News of the National Academy of Sciences of the Republic of Kazakhstan. Series of geology and technology sciences.

ISSN 2518-170X (Online),

ISSN 2224-5278 (Print)

Меншіктеуші: «Орталық Азия академиялық ғылыми орталығы» ЖШС (Алматы қ.).

Қазақстан Республикасының Ақпарат және коммуникациялар министрлігінің Ақпарат комитетінде 05.06.2025 ж. берілген № KZ50VPY00121155 мерзімдік басылым тіркеуіне қойылу туралы куәлік. Тақырыптық бағыты: *геология, гидрогеология, география, тау-кен ісі, мұнай, газ және металдардың химиялық технологиялары*

Мерзімділігі: жылына 6 рет.

<http://www.geolog-technical.kz/index.php/en/>

ГЛАВНЫЙ РЕДАКТОР

ЖУРИНОВ Мурат Журинович, доктор химических наук, профессор, академик МАН и НАН РК, Генеральный директор НИИ нефтепереработки и нефтехимии (Алматы, Казахстан), <https://www.scopus.com/authid/detail.uri?authorId=6602177960>; <https://www.webofscience.com/wos/author/record/2017489>

ЗАМЕСТИТЕЛЬ ГЛАВНОГО РЕДАКТОРА

АБСАДЫКОВ Бахыт Нарикбаевич, доктор технических наук, профессор, академик НАН РК, Казахский национальный исследовательский технический университет им. К.И. Сатпаева (Алматы, Казахстан), <https://www.scopus.com/authid/detail.uri?authorId=6504694468>; <https://www.webofscience.com/wos/author/record/2411827>

РЕДАКЦИОННАЯ КОЛЛЕГИЯ:

АБСАМЕТОВ Малис Кудысович, доктор геолого-минералогических наук, профессор, академик НАН РК, директор Института гидрогеологии и геоэкологии им. У.М. Ахмедсафина (Алматы, Казахстан), <https://www.scopus.com/authid/detail.uri?authorId=56955769200>; <https://www.webofscience.com/wos/author/record/1937883>

ЖОЛТАЕВ Герой Жолтаевич, доктор геолого-минералогических наук, профессор, почетный академик НАН РК (Алматы, Казахстан), <https://www.scopus.com/authid/detail.uri?authorId=57112610200>; <https://www.webofscience.com/wos/author/record/1939201>

СНОУ Дэниел, PhD, ассоциированный профессор, директор Лаборатории водных наук Университета Небраски (Небраска, США), <https://www.scopus.com/authid/detail.uri?authorId=7103259215>; <https://www.webofscience.com/wos/author/record/1429613>

ЗЕЛЬТМАНН Раймар, PhD, руководитель исследований в области петрологии и месторождений полезных ископаемых в Отделе наук о Земле Музея естественной истории (Лондон, Великобритания), <https://www.scopus.com/authid/detail.uri?authorId=55883084800>; <https://www.webofscience.com/wos/author/record/1048681>

ПАНФИЛОВ Михаил Борисович, доктор технических наук, профессор Университета Нанси (Нанси, Франция), <https://www.scopus.com/authid/detail.uri?authorId=7003436752>; <https://www.webofscience.com/wos/author/record/1230499>

ШЕН Пин, PhD, заместитель директора Комитета по горной геологии Китайского геологического общества, член Американской ассоциации экономических геологов (Пекин, Китай), <https://www.scopus.com/authid/detail.uri?authorId=57202873965>; <https://www.webofscience.com/wos/author/record/1753209>

ФИШЕР Аксель, PhD, ассоциированный профессор, Технический университет Дрезден (Дрезден, Берлин), <https://www.scopus.com/authid/detail.uri?authorId=35738572100>; <https://www.webofscience.com/wos/author/record/2085986>

АГАБЕКОВ Владимир Еноквич, доктор химических наук, академик НАН Беларуси, почетный директор Института химии новых материалов (Минск, Беларусь), <https://www.scopus.com/authid/detail.uri?authorId=7004624845>

КАТАЛИН Стефан, PhD, ассоциированный профессор, Технический университет Дрезден (Дрезден, Германия), <https://www.scopus.com/authid/detail.uri?authorId=35203904500>; <https://www.webofscience.com/wos/author/record/1309251>

САГИНТАЕВ Жанай, PhD, ассоциированный профессор, Назарбаев университет (Астана, Казахстан), <https://www.scopus.com/authid/detail.uri?authorId=57204467637>; <https://www.webofscience.com/wos/author/record/907886>

ФРАТТИНИ Паоло, PhD, ассоциированный профессор, Миланский университет Бикокк (Милан, Италия), <https://www.scopus.com/authid/detail.uri?authorId=56538922400>

НУРПЕИСОВА Маржан Байсановна, доктор технических наук, профессор Казахского национального исследовательского технического университета им. К.И. Сатпаева (Алматы, Казахстан), <https://www.scopus.com/authid/detail.uri?authorId=57202218883>; <https://www.webofscience.com/wos/author/record/AAD-1173-2019>

РАТОВ Боранбай Товбасарович, доктор технических наук, профессор, заведующий кафедрой «Геофизика и сейсмология», Казахский национальный исследовательский технический университет им. К.И. Сатпаева (Алматы, Казахстан), <https://www.scopus.com/authid/detail.uri?authorId=55927684100>; <https://www.webofscience.com/wos/author/record/1993614>

РОННИ Бердтссон, профессор, Директор Центра современных ближневосточных исследований, Лундский университет (Лунд, Швеция), <https://www.scopus.com/authid/detail.uri?authorId=7005388716>; <https://www.webofscience.com/wos/author/record/1324908>

МИРЛАС Владимир, PhD, профессор, Восточный научно-исследовательский центр, Университет Ариэля (Ариэль, Израиль), <https://www.scopus.com/authid/detail.uri?authorId=8610969300>; <https://www.webofscience.com/wos/author/record/53680261>

News of the National Academy of Sciences of the Republic of Kazakhstan. Series of geology and technology sciences.

ISSN 2518-170X (Online),

ISSN 2224-5278 (Print)

Собственник: ТОО «Центрально-Азиатский академический научный центр» (г. Алматы).

Свидетельство о постановке на учет периодического печатного издания в Комитете информации Министерства информации и коммуникаций и Республики Казахстан № KZ50VPY00121155, выданное 05.06.2025 г.

Тематическая направленность: *геология, гидрогеология, география, горное дело и химические технологии нефти, газа и металлов*

Периодичность: 6 раз в год.

<http://www.geolog-technical.kz/index.php/en/>

CONTENTS

Abetov A.E., Seitzhanov A.K., Samenov Y.R., Zhassymbek S.A. Machine learning and neural networks for lithofacies mapping and reservoir property evaluation of core samples.....	8
Aitkaliyev A.K., Pak Y.N., Kolmakov Y.V., Pak D.Y., Matishev T.V. Application of the X-Ray radiometric method to improve the operational quality control of copper ores during geological testing.....	26
Altay Y.A., Karymsakova N.T., Fedorov A.V., Absadykov D.B., Ismagul G.K. Predictive control of diagnostically significant parameters of acoustic emission using machine learning: new data.....	41
Astanakulov K.D., Kodirova M.G., Saydumarov B., Nersesyan D.V., Kurashkin S.O. Resource potential of ecological and geological systems of allocated soil masses.....	58
Avazov Sh.B., Yodgorov Sh.I., Mukhammadkulov N.M., Aktamov B.U., Khayriddinov B.B. Instrumental seismometric assessment of the impact of technogenic seismic vibrations on the structural stability of historical objects.....	74
Baskanbayeva D., Kalmaganbetov S., Sabirova L., Zholdybayeva G., Koptleuov K. CFD analysis of screw compressor rotor geometry influence on gas compression efficiency in geology.....	92
Borotov A.N., Karshiev F.U., Igamberdiyev A.A., Grigoryan A.G., Sarigo N.V. Ecological aspects of resource conservation in the development of mineral deposits.....	107
Gerasidi V.V., Lisachenko A.V., Apatenko A.S., Sevryugina N.S., Fomin A.Y. Analysis of the application of non-destructive testing methods for assessing the technical condition of mining equipment motors based on vibration parameters.....	121
Hajiyeva A.Z., Ibrahimova L.P., Humbatova Sh.Y., Jafarova F.M. Ecological processes of vertical landscape transformation and their manifestation in the natural landscapes of Nakhchivan.....	135
Jakiyayev D.K., Nussipali R.K.*, Malibekov A.K., Jakiyayev B.D., Zhashen S.Zh. Statistical model of multi-cycle fatigue of steel structural elements under a complex non-uniform stress state.....	149
Jumatov Y.K., Tashbulatov S.B., Pushanov A.N., Kozenkova G.L., Yarygina I.V. Technological substantiation of sustainable mining reclamation of disturbed lands in open pit operations.....	169
Kainenova T.S., Kosmbaeva G.T., Bissembayeva K.T., Otarbayeva A.T., Orazbek A.A. Effectiveness of measures to regulate the development process at the Alibekmola field.....	185

Koishiyeva G.Zh., Yerimova A.Zh., Kurbaniyazov S.K., Agaidarova K.H., Abdraimova K.T.	
Radiological properties and stratigraphic significance of glauconite-bearing formations: implications for paleoenvironments and geochemical zonation.....	203
Kondratiev V.V., Bryukhanova N.N., Kononenko R.V., Gladkikh V.A., Matasova I.Y.	
Environmental and technological assessment of beneficiation tailings reprocessing based on mechanical activation and non-ferrous metals leaching.....	223
Kuldeyev Ye., Negmatov S., Nurpeissova M., Kirgizbaeva D., Donenbayeva N.	
Geodynamic Polygon of the Zhilandy Ore Field: Results and Prospects.....	237
Madibekov A., Christian Opp., Karimov A., Ismukhanova L., Zhadi A.	
Regularities of distribution and accumulation factors of heavy metals in soils of the Zhetysu region (Kazakhstan).....	253
Malikov G.I., Musayeva S.A., Mammadov K.S., Jabiyeva U.M., Jafarova K.V.	
Effects of hydrocarbon fuel quality fluctuations on energy generation efficiency, economic viability, and environmental footprint.....	272
Narbaev M.T., Ismailova G.K., Narbaeva K.T., Burlibayeva D.M., Groll M.	
Assessment of ecological and water management parameters of the Syrdarya River.....	290
Nurmagambetov A.	
On seismic hazard of Almaty and tectonic faults in the city.....	309
Permana A.P., Kasim M., Hutagalung R., Uno D.A.N., Sandi I.N.	
petrographic, provenance, and tectonic setting of Dolokapa formation sandstone, North Gorontalo.....	319
Ratov B.T., Khomenko V.L., Yavorska O.O., Koroviaka Ye.A., Akhmetova N.S.	
Analytical and structural justification of a wellhead sealing device for large-diameter drilling operations.....	335
Skrobala V.M., Popovych V.V., Kopylov V.P., Popovych N.P.	
Comprehensive assessment of heavy metal pollution of a river within a large city.....	355
Sunakbaeva D.Kh., Yuldashbek D.Kh., Aitekova K., Seitbayev K.Zh.	
Monitoring heavy metals in soils and waters of the City of Turkestan: geoecological aspect.....	371
Zakirov M.M., Agzamova I.A., Ochilov G.E., Gulyamov G.D., Xudayberdiyev T.M.	
Analysis of the results of changes in the gas and isotopic composition of groundwater during the period of earthquake preparation.....	385
Zhanbatyrov A.A., Tukhfatov Zh.K., Bektay E.K., Turisbekova G.S., Zhanbatyrov N.A.	
Current state of potash ore development in the Caspian lowlands of the Republic of Kazakhstan: problems and solutions.....	309

NEWS OF THE NATIONAL ACADEMY OF SCIENCES OF THE REPUBLIC
OF KAZAKHSTAN, SERIES OF GEOLOGY AND TECHNICAL SCIENCES
ISSN 2224-5278
Volume 2.
Number 476 (2026), 335–354

<https://doi.org/10.32014/2026.2518-170X.632>

UDC: 622.245.7

IRSTI: 52.47.15

©Ratov B.T.¹, Khomenko V.L.^{2*}, Yavorska O.O.², Koroviaka Ye.A.²,
Akhmetova N.S.¹, 2026.

¹Satbayev University, Almaty, Kazakhstan;

²Dnipro University of Technology, Dnipro, Ukraine.

*E-mail: intelldriller@gmail.com

ANALYTICAL AND STRUCTURAL JUSTIFICATION OF A WELLHEAD SEALING DEVICE FOR LARGE-DIAMETER DRILLING OPERATIONS

Ratov Boranbay — Doctor of Technical Sciences, Professor, Satbayev University, Almaty, Kazakhstan,

E-mail: b.ratov@satbayev.university, <https://orcid.org/0000-0003-4707-3322>;

Khomenko Volodymyr — Candidate of Technical Sciences, Associate Professor, Dnipro University of Technology, Dnipro, Ukraine,

E-mail: intelldriller@gmail.com, <https://orcid.org/0000-0002-3607-5106>;

Yavorska Olena — Doctor of Technical Sciences, Professor, Dnipro University of Technology, Dnipro, Ukraine,

E-mail: yavorska.o.o@nmu.one, <https://orcid.org/0000-0001-5516-5310>;

Koroviaka Yevhenii — Candidate of Technical Sciences, Associate Professor, Dnipro University of Technology, Dnipro, Ukraine,

E-mail: koroviaka.ye.a@nmu.one, <https://orcid.org/0000-0002-2675-6610>;

Akhmetova Nazar — PhD student, Satbayev University, Aktau, Kazakhstan,

E-mail: nazar.akhmetova@gmail.com, <https://orcid.org/0009-0004-8906-0014>.

Abstract. With the growing demand for reliable, high-yield groundwater sources, advances in drilling large-diameter wells have become particularly relevant. One of the key challenges remains the insufficient efficiency of conventional wellhead sealing systems, which fail to maintain stable circulation pressure and thereby limit the achievable drilling depth. This issue is especially critical in water-scarce regions, where the development of wells with diameters exceeding 600 mm and depths greater than 200 m is required. This study proposes a novel packer-type wellhead sealing device designed to generate controlled pressure during reverse-circulation drilling. The research methodology included analytical evaluation of the packer's stress–strain state, analysis of contact pressures on the conical surface, and a comparative review of existing technical

solutions. The performance assessment was based on classical elasticity theory models and applicable international standards for elastomer component design. Theoretical modeling of mechanical stress distribution within the packer material indicates that, at operating pressures of 0.8–1.0 MPa, the sealing element maintains sufficient elasticity and structural stability. The calculated contact pressure distribution along the conical surface decreases gradually toward the upper edge, ensuring uniform packer compression and preventing localized overstressing. The proposed design enables the use of standard centrifugal pump pressure to establish circulation, thereby significantly increasing the achievable drilling depth of large-diameter wells. Practical implementation of the device enhances wellhead sealing reliability, reduces drilling fluid losses, improves borehole stability, and mitigates environmental risks. The proposed technical solution is suitable for application in water supply systems in Kazakhstan, Central Asia, and other arid regions.

Keywords: wellhead sealing, large-diameter water well, packer, conical sealing element, stress analysis, contact pressure distribution

For citations: Ratov B.T., Khomenko V.L., Yavorska O.O., Koroviaka Ye.A., Akhmetova N.S. Analytical and Structural Justification of a Wellhead Sealing Device for Large-Diameter Drilling Operations. *News of the National Academy of Sciences of the Republic of Kazakhstan, Series of Geology and Technical Sciences.* 2026. No.2. Pp. 335–354. DOI: <https://doi.org/10.32014/2026.2518-170X.632>

©Ратов Б.Т.¹, Хоменко В.Л.^{2*}, Яворская Е.А.², Коровяка А.Е.²,
Ахметова Н.С.¹, 2026.

¹Қ.И. Сәтбаев атындағы Қазақ ұлттық техникалық зерттеу университеті,
Алматы, Қазақстан;

²«Днепровская политехника» Ұлттық техникалық университеті,
Днепр, Украина.

*E-mail: intelldriller@gmail.com

ҮЛКЕН ДИАМЕТРЛІ ҰҢҒЫМАЛАРДЫ БҰРҒЫЛАУҒА АРНАЛҒАН ҰҢҒЫМА САҒАСЫН НЫҒЫЗДАУ ҚҰРЫЛҒЫСЫН АНАЛИТИКАЛЫҚ-ҚҰРЫЛЫМДЫҚ НЕГІЗДЕУ

Ратов Боранбай — техника ғылымдарының докторы, профессор, Satbayev University, Алматы, Қазақстан,

E-mail: b.ratov@satbayev.university, <https://orcid.org/0000-0003-4707-3322>;

Хоменко Владимир — техника ғылымдарының кандидаты, доцент, «Днепровская политехника» Ұлттық техникалық университеті, Днепр, Украина,

E-mail: intelldriller@gmail.com, <https://orcid.org/0000-0002-3607-5106>;

Яворская Елена — техника ғылымдарының докторы, профессор, «Днепровская политехника» Ұлттық техникалық университеті, Днепр, Украина,

E-mail: yavorska.o.o@nmu.one, <https://orcid.org/0000-0001-5516-5310>;

Коровяка Евгений — техника ғылымдарының кандидаты, доцент, «Днепровская политехника» Ұлттық техникалық университеті, Днепр, Украина,

E-mail: koroviaka.ye.a@nmu.one, <https://orcid.org/0000-0002-2675-6610>;

Ахметова Назар — PhD докторант, Satbayev University, Алматы, Қазақстан,

E-mail: nazar.akhmetova@gmail.com, <https://orcid.org/0009-0004-8906-0014>.

Аннотация. Жерасты суларының сенімді әрі жоғары дебитті көздеріне деген сұраныстың артуы жағдайында ірі диаметрі ұғымдарды бұрғылау технологияларын жетілдіру ерекше өзектілікке ие болып отыр. Негізгі мәселелердің бірі — дәстүрлі сағалық герметизациялау жүйелерінің жеткіліксіз тиімділігі, олар айналым қысымының тұрақтылығын қамтамасыз етпей, бұрғылау тереңдігін шектейді. Бұл проблема су ресурстары тапшы аймақтарда аса маңызды, себебі мұндай өңірлерде диаметрі 600 мм-ден асатын және тереңдігі 200 м-ден жоғары ұңғымаларды пайдалану қажет. Бұл жұмыста кері айналым әдісімен бұрғылау кезінде реттелетін қысым қалыптастыруды қамтамасыз ететін пакерлік типтегі жаңа салалық герметизатор конструкциясы ұсынылады. Зерттеу әдістемесі пакердің кернеулі-деформацияланған күйін аналитикалық есептеуді, конустық беттегі жанасу қысымдарын талдауды және қолданыстағы техникалық шешімдерге салыстырмалы шолу жасауды қамтыды. Тиімділікті бағалау үшін серпімділік теориясының классикалық модельдері және эластомерлі элементтерді есептеуге арналған қолданыстағы халықаралық стандарттар пайдаланылды. Пакер материалы ішіндегі механикалық кернеулердің таралуын теориялық модельдеу нәтижесінде жұмыс қысымы 0,8–1,0 МПа дейін болған жағдайда тығыздағыш элементтің қажетті серпімділігі мен құрылымдық орнықтылығы сақталатыны анықталды. Конустық бет бойымен жанасу қысымының таралуын есептеу оның жоғарғы жиегіне қарай біртіндеп төмендейтінін көрсетті, бұл пакердің біркелкі қысыла отырып, жергілікті артық кернеулердің алдын алуын қамтамасыз етеді. Ұсынылған конструкция стандартты орталықтан тепкіш сорғылардың напорын айналымды қалыптастыру үшін пайдалануға мүмкіндік береді, соның нәтижесінде ірі диаметрі ұңғымаларды бұрғылаудың мүмкін болатын тереңдігі едәуір артады. Құрылымын практикалық қолдану сағалық герметизацияның сенімділігін арттыруға, бұрғылау ерітіндісінің шығындарын азайтуға, ұңғыма оқпанының орнықтылығын жақсартуға және экологиялық тәуекелдерді төмендетуге ықпал етеді. Ұсынылған техникалық шешім Қазақстанның, Орталық Азияның және басқа да аридтік аймақтардың сумен жабдықтау жүйелерінде қолдануға жарамды.

Түйін сөздер: ұңғыма сағасы, үлкен диаметрі су алу ұңғымасы, пакер, конустық тығыздағыш, кернеуді талдау, жанасу қысымын бөлу

©Ратов Б.Т.¹, Хоменко В.Л.^{2*}, Яворская Е.А.², Коровяка А.Е.²,
Ахметова Н.С.¹, 2026.

¹НАО «Казахский национальный исследовательский технический университет имени К.И. Сатпаева», Алматы, Казахстан;

²Национальный технический университет «Днепровская политехника»,
Днепр, Украина.

*E-mail: intelldriller@gmail.com

АНАЛИТИЧЕСКОЕ И СТРУКТУРНОЕ ОБОСНОВАНИЕ УСТЬЕВОГО ГЕРМЕТИЗИРУЮЩЕГО УСТРОЙСТВА ДЛЯ БУРЕНИЯ СКВАЖИН БОЛЬШОГО ДИАМЕТРА

Ратов Боранбай — доктор технических наук, профессор, Satbayev University, Алматы, Казахстан,

E-mail: b.ratov@satbayev.university, <https://orcid.org/0000-0003-4707-3322>;

Хоменко Владимир — кандидат технических наук, доцент, Национальный технический университет «Днепровская политехника», Днепр, Украина,

E-mail: intelldriller@gmail.com, <https://orcid.org/0000-0002-3607-5106>;

Яворская Елена — доктор технических наук, профессор, Национальный технический университет «Днепровская политехника», Днепр, Украина,

E-mail: yavorska.o.o@nmu.one, <https://orcid.org/0000-0001-5516-5310>;

Коровяка Евгений — кандидат технических наук, доцент, Национальный технический университет «Днепровская политехника», Днепр, Украина,

E-mail: koroviaka.ye.a@nmu.one, <https://orcid.org/0000-0002-2675-6610>;

Ахметова Назар — PhD докторант, Satbayev University, Алматы, Казахстан,

E-mail: nazar.akhmetova@gmail.com, <https://orcid.org/0009-0004-8906-0014>.

Аннотация. *Актуальность.* В условиях роста потребности в надёжных и высокодебитных источниках подземных вод задача совершенствования технологий бурения крупноразмерных скважин приобретает особую актуальность. Одной из ключевых проблем остаётся недостаточная эффективность традиционных систем герметизации устья, которые не обеспечивают стабильного давления циркуляции и ограничивают достижимую глубину бурения. Это особенно критично для регионов с дефицитом водных ресурсов, где требуется эксплуатация скважин диаметром свыше 600 мм и глубиной более 200 м. *Цель.* Разработать и обосновать конструкцию устьевого герметизатора пакерного типа, обеспечивающего создание контролируемого давления при бурении методом обратной циркуляции. *Методы.* Методология исследования включала аналитический расчёт напряжённо-деформированного состояния пакера, анализ контактных давлений на конической поверхности и сравнительный анализ существующих технических решений. Для оценки эффективности использованы положения классической теории упругости и действующие международные стандарты расчёта эластомерных элементов. *Результаты и выводы.* На основе теоретического моделирования распределения механических напряжений в

материале пакера установлено, что при рабочих давлениях до 0,8–1,0 МПа уплотнительный элемент сохраняет необходимую упругость и структурную устойчивость. Расчёт распределения контактного давления по конической поверхности показал его постепенное снижение к верхнему краю, что обеспечивает равномерное прижатие пакера и предотвращает локальные перенапряжения. Предложенная конструкция позволяет использовать напор стандартных центробежных насосов для создания циркуляции, что значительно увеличивает возможную глубину бурения крупноразмерных скважин. Практическое применение устройства способствует повышению надёжности устьевого герметизации, сокращению потерь бурового раствора, улучшению устойчивости ствола скважины и снижению экологических рисков. Разработанное техническое решение может быть внедрено в системах водоснабжения Казахстана, Центральной Азии и других аридных регионов.

Ключевые слова: герметизатор устья, водозаборная скважина большого диаметра, пакер, коническое уплотнение, анализ напряжений, распределение контактного давления

Introduction. The construction of large-diameter water wells represents one of the most technically demanding and strategically important directions in modern hydrogeological engineering. With the global growth of urban populations, agricultural intensification, and industrial expansion, the demand for reliable and high-yield groundwater sources continues to increase. In regions with limited surface water availability or strong seasonal variability in precipitation, large-diameter wells serve as critical infrastructure for ensuring stable and sustainable water supply. Their role extends far beyond local water access: they form the backbone of centralized municipal systems, supply industrial facilities, and support agricultural irrigation projects that determine the socio-economic stability of entire regions.

The increasing scarcity of high-quality groundwater resources has placed new emphasis on the efficiency, safety, and environmental compatibility of drilling operations (Hapich et al, 2024). In many developing and arid regions, including large areas of Central Asia, traditional small-diameter well technologies have proven inadequate to meet industrial-scale demands. Large-diameter wells—typically exceeding 600 mm in diameter—enable higher discharge rates, greater storage capacity, and the possibility of integrating advanced pumping and filtration systems. However, such advantages come with significant engineering challenges. The increase in borehole diameter amplifies the effects of geological heterogeneity, mechanical instability, and hydraulic loading. These wells must maintain structural integrity through variable lithological layers while preventing formation damage and minimizing contamination risks to aquifers.

The complexity of the process is determined not only by the geological setting but also by the interrelated design factors—drilling method, drilling fluid properties,

casing system, and well development technique. For instance, conventional rotary drilling methods, which are widely used for smaller water wells, often prove inefficient and unstable at larger diameters due to inadequate cuttings removal and excessive drilling fluid losses. In contrast, reverse circulation rotary drilling offers improved borehole stability and higher penetration rates, yet it requires careful optimization of hydraulic parameters, equipment configuration, and drilling fluid composition (Davydenko et al, 2015).

One of the main challenges in the field is maintaining borehole stability in weak or unconsolidated formations. Collapses and washouts can significantly increase construction time and costs, and in some cases, lead to complete failure of the well. The choice of drilling fluid becomes a decisive factor. While traditional bentonite-based systems provide good wall support, they can reduce permeability of the aquifer zone, leading to a decline in well efficiency. Recent studies have focused on low-viscosity polymer-based fluids and biodegradable additives, which minimize formation clogging and facilitate post-drilling well development. However, their performance under specific hydrogeological conditions, such as those found in Central Asia—characterized by alternating sandy, clayey, and gravelly deposits—remains insufficiently explored.

Equally important is the design of the casing and screen system. In large-diameter wells, the casing structure must withstand significant mechanical stresses while maintaining hydraulic efficiency and resistance to corrosion. The choice of materials—whether steel, reinforced concrete, or fiberglass—depends on both mechanical requirements and water chemistry. Improper casing selection or installation can lead to long-term operational problems, including corrosion, sand production, and biofouling. Therefore, comprehensive design optimization that integrates geological data, material science, and hydraulic modeling is essential for reliable well performance.

The industrial significance of improving large-diameter well drilling technologies is particularly evident in the context of Kazakhstan and the broader Central Asian region (Ratov et al, 2024). Rapid urbanization, expansion of agriculture, and industrial development have sharply increased the pressure on existing water resources. Many regional water supply systems rely on outdated or inefficient drilling technologies, which often result in low well productivity, poor borehole stability, and high maintenance costs. In some cases, wells constructed under inadequate technological control have failed within a few years of operation due to mechanical collapse or clogging of the filter zone. The modernization of drilling practices through the introduction of scientifically justified, field-tested methods can therefore have a direct and measurable impact on water security, economic efficiency, and environmental sustainability.

In addition to the practical challenges, the scientific interest in large-diameter water well construction arises from the complex interaction of physical, chemical, and mechanical processes that govern borehole stability and aquifer performance.

The drilling operation alters the natural stress regime, hydraulic gradients, and geochemical equilibrium of the subsurface environment. Understanding these interactions is essential for developing predictive models that allow engineers to anticipate potential problems and design preventive measures. For example, the study of mud-filtrate invasion and its impact on aquifer permeability provides valuable insights into optimizing drilling fluid formulations. Similarly, the analysis of casing deformation and grout behavior under variable stress conditions informs the choice of materials and installation techniques.

Literary review. Despite numerous international studies and technological advances, there remains a clear need for regionally adapted methodologies that take into account the specific geological and climatic conditions of Central Asia. Many existing guidelines have been developed for temperate or coastal regions with different lithological profiles and groundwater regimes. The transfer of such technologies without appropriate adaptation often leads to inefficiencies or environmental risks. Therefore, the development of an applied methodological framework tailored to local conditions is both scientifically relevant and industrially urgent.

The problem of effective wellhead sealing and fluid circulation in large-diameter well drilling has been discussed in international literature over the last three decades, primarily in connection with groundwater extraction, geothermal energy development, and geotechnical exploration. Although the majority of engineering studies and patents focus on hydrocarbon wells, many of the underlying principles—pressure control, annular sealing, and lubrication-assisted packers—are equally applicable to the construction of large-diameter water wells.

Modern drilling technologies for large-diameter water wells (typically exceeding 500–600 mm) have evolved significantly since the early 1990s. Reverse circulation rotary (RCR) drilling remains the dominant method, as it allows efficient removal of cuttings from deep, wide boreholes while maintaining good wall stability. According to (Hou et al, 2024), RCR drilling provides better control over drilling hydraulics and reduces the risk of formation collapse, but requires precise regulation of flow velocity and pump pressure to prevent fluid losses and sand intrusion. Similarly, (Pukish et al, 2024) emphasized that hydraulic stability in wide-diameter wells depends heavily on consistent wellhead pressure and adequate fluid density, especially in unconsolidated formations.

Several recent studies have focused on optimizing circulation and pressure regimes in large-diameter wells through the use of variable-speed pumps and closed-loop circulation systems. The authors of the paper (Umirova et al, 2025) demonstrated that maintaining controlled positive pressure at the wellhead significantly increases drilling depth capacity in water wells, as it prevents air entrainment and stabilizes the fluid column.

Despite these advances, the majority of RCR drilling systems remain open to atmospheric pressure at the surface. This configuration simplifies operation

but limits maximum achievable depth because the driving pressure is restricted to the hydrostatic head of the drilling fluid. Moreover, open systems are prone to air leakage, fluid spillage, and contamination—issues that become critical in environmental and potable water applications. These shortcomings underline the necessity for a hermetically sealed wellhead capable of operating under controlled hydraulic pressure.

The sealing of the wellhead plays a central role in maintaining circulation efficiency and preventing fluid contamination. Conventional systems employ simple mechanical rubber seals or flexible packers to isolate the annular space between the drill pipe and casing (Vytyaz et al, 2024). In hydrocarbon drilling, various dynamic sealing mechanisms have been developed to withstand rotational and axial movement while maintaining pressure integrity. The authors of the paper (Wu et al, 2021) analyzed rotary blowout preventers and rotating heads, showing that dynamic seals can maintain effective closure up to pressures of 2–3 MPa with minimal wear when properly lubricated. However, the design complexity and cost of such devices make them unsuitable for water well applications.

In the context of groundwater and geothermal wells, simpler packer configurations are preferred. The authors of the paper (He et al, 2025) reviewed the use of inflatable and mechanical packers for borehole sealing in hydraulic testing, highlighting their adaptability but also their limitations in rotational drilling, where friction and torsion quickly degrade the seal. The authors of the paper (Bondarenko et al, 2024) further noted that most packers used in hydrological applications are static; they are installed after drilling and are not designed to accommodate continuous rotation or pipe movement. Consequently, their direct adaptation to large-diameter rotary drilling remains problematic.

A promising direction involves the use of elastomeric conical packers that rotate together with the drill pipe, minimizing relative motion at the contact interface. The authors of the article (Liu et al, 2022) created a rotating conical seal for coalbed methane underbalanced drilling, where the packer is lubricated by oil injection to reduce wear and maintain a stable pressure seal. This concept bears a strong similarity to the present design, although the patented system was limited to smaller diameters (<300 mm) and required complex hydraulic control for inflation. The integration of such a principle into large-diameter water wells, where rotation speed is low and frictional heating minimal, presents a realistic and cost-effective adaptation opportunity.

Hydraulic control at the wellhead is the most critical factor determining drilling efficiency and borehole stability in large-diameter wells. The authors of the paper (Kozhevnykov et al, 2018) performed numerical simulations of large-scale well hydraulics and found that insufficient circulation pressure leads to poor cuttings transport and uneven borehole cleaning, which can result in localized wall collapse. Conversely, controlled overpressure at the wellhead stabilizes the annulus and allows deeper drilling without increasing mud density, thus avoiding aquifer clogging.

The authors of the paper (Ihnatov et al, 2023) reported similar results, where surface pressurization enabled deeper penetration and reduced non-productive time. They concluded that the key to extending drilling depth lies not only in pump capacity but also in maintaining seal integrity under fluctuating pressures. The combination of these factors underscores the engineering relevance of wellhead hermetization using a pressure-assisted design.

The field of rotating seals, packer units, and dynamic sealing devices had undergone intensive theoretical, numerical, and experimental research—especially in contexts such as blowout preventers (BOPs), rotary sealing heads, and high-pressure dynamic seals in mechanical systems.

The authors of the paper (Hu et al, 2021) presented a detailed finite element simulation of a packing unit used in RBOP systems. They selected a Yeoh constitutive model for the rubber material after tensile testing, built a contact model between the packer and drill pipe, and studied how well pressure, tripping speed, friction coefficient, and structural geometry influenced contact stress distributions and failure modes. One key finding was that contact stress peaked when tool joints traversed the packing unit, and failure often occurred by shear at the inner angles or alternating von Mises stress with shear on lower edges.

The authors of the article (Jiang et al, 2025) proposed a rotary sealing system that dynamically compensated for wear by axial adjustment of a guide sleeve under pressure. They coupled fluid–structure interaction, analyzed leakage behavior and frictional heating, and selected optimal sealing materials (PVDF, PEEK, PE, PA). Their experiments showed that as fluid pressure increased, leakage decreased sharply, and that friction torque was sensitive to pressure but nearly independent of rotation speed.

The authors of the paper (Feng et al, 2022) reported on an advanced dynamic seal intended for very high pressure (experimental testing of sealing performance under different pressures) and discussed the coupling of structural deformation and leakage control. Their work was relevant to high-pressure sealing challenges and provided empirical data for verifying sealing designs that had to resist deformation and leakage under extreme pressures.

The author of the article (Bourgoyne, 1995) explored how damage (scratches, wear) to the upper sealing surfaces influenced contact pressure distribution and leakage of BOP ram seals. Their study underscored the importance of surface condition, wear, and local defects in long-term seal performance—an aspect that was relevant when considering durability of hermetizer’s seal surfaces.

While the literature review provides a strong foundation for understanding hydraulic and mechanical challenges in large-diameter drilling, it reveals a noticeable lack of practical solutions for water wells operating at industrial depths (>200 m) and diameters exceeding 600 mm. Most advanced sealing systems have been developed for hydrocarbon or geothermal industries, where cost and complexity are acceptable trade-offs. In contrast, water well construction demands simpler, more robust, and maintenance-friendly designs.

The majority of available packers are static, non-rotational, or inflatable, with limited mechanical strength under dynamic conditions. Moreover, few designs allow for continuous lubrication of the sealing surface or pressure regulation directly at the wellhead. Therefore, there exists a clear technological gap that can be addressed by the development of a hermetic, lubricated, pressure-controlled wellhead system specifically adapted for large-diameter water wells.

The proposed device responds to this need by integrating several proven engineering principles—mechanical conical sealing, controlled compression through adjustable bolts, and lubrication-assisted wear reduction—into a single, compact assembly. Such integration not only improves hydraulic performance and drilling depth but also enhances environmental safety by eliminating surface fluid discharge.

This review demonstrates that while the general problem of borehole sealing is well-studied in oil and geothermal engineering, its application to water well drilling at large diameters remains insufficiently developed. Thus, the present study contributes to filling this gap by providing a theoretically validated design concept and analytical framework for future field implementation.

The present study aims to substantiate and theoretically evaluate the effectiveness of a newly developed wellhead sealing device (packer-type wellhead hermetizer) designed to enable drilling of large-diameter water wells under controlled pressure conditions. The invention addresses the principal limitation of conventional large-bore well drilling systems, in which circulation of drilling fluid is governed by hydrostatic or atmospheric pressure differences, thus restricting achievable well depth and operational reliability.

Materials and methods. This study focuses on the analytical evaluation and conceptual design of a wellhead sealing system intended for drilling large-diameter water wells. The research combines a systematic analysis of existing international designs with a detailed structural and functional examination of a newly proposed hermetic sealing device.

The initial stage of the research consisted of a comprehensive literature and patent review focused on wellhead sealing systems used in the drilling of large-diameter water and geothermal wells. Data were collected from open-access engineering databases (ScienceDirect, SpringerLink, Espacenet, Patentscope et al.). The primary goal of the review was to identify the prevailing technical concepts, such as inflatable or mechanical packers, rotary seals, and lubrication-assisted contact surfaces, and to evaluate their applicability in large-scale water well construction.

The analytical modeling of mechanical stresses in the packer material and the supporting structure was performed using classical elasticity theory and empirical correlations from established mechanical design standards (ASME Boiler and Pressure Vessel Code, Section VIII, and ISO 15156 for elastomeric components). The sealing pressure distribution along the conical surface was calculated assuming

uniform bolt loading, with corrections for rotational shear stress generated by the drill pipe movement. The estimated contact stress values (to be inserted based on laboratory elastomer properties) were compared with typical allowable limits for oil-resistant rubber compounds operating at low rotation speeds (typically < 60 rpm). The analysis confirmed that the proposed conical geometry significantly reduces localized stress peaks, thereby improving the long-term durability of the seal under continuous rotational contact.

Overall, the research methodology integrates theoretical modeling with design analysis to evaluate the operational feasibility of the wellhead sealing system. While no experimental verification has been performed within the current phase of work, the results establish a scientifically grounded framework for further prototyping and field validation. The developed analytical approach provides a reliable foundation for scaling the technology and adapting it to specific geological and hydraulic conditions encountered in Central Asia and other arid regions.

Results. Drilling of large-diameter water wells is always performed using a reverse circulation system (Pashchenko et al, 2024). Reverse circulation can be implemented either by suction or by an airlift method. Both methods impose inherent limitations on drilling depth: the former—because the return flow is driven by vacuum, which cannot exceed one atmosphere; the latter—due to the limited capacity of compressors, whose discharge pressure typically does not exceed 1 MPa. Compressors capable of producing higher pressures are technically complex and extremely expensive.

The use of a wellhead sealing device (hermetizer) allows reverse circulation to be created by means of conventional centrifugal pumps, which can generate sufficiently high discharge pressure to substantially increase the attainable drilling depth for large-diameter wells.

In the wellhead hermetizer developed by the authors, the circulation of drilling fluid is maintained not by atmospheric or hydrostatic pressure differentials between aerated and non-aerated columns, but by the discharge pressure of the drilling pump, which can be high enough to multiply the achievable depth of large-diameter wells (Fig. 1).

The hermetizer is mounted on the guide casing (1). An inlet pipe (4) is welded to the casing wall. At the upper end of the pipe, a base plate (5) is bolted using a sealing gasket (16); the housing (6) is welded to this base. Inside the conical bore of the housing is a packer (7) made of oil-resistant rubber. Lubricating oil from the lubricator (15) is supplied through a radial port (14) to reduce friction between the stationary conical surface of the housing and the rotating packer, which turns together with the kelly (2). The packer is bored with a square opening matching the cross-section of the kelly.

To apply a sealing force to the packer, threaded bushings (8) are welded on diametrically opposite sides of the housing. Clamping bolts (9) threaded into these bushings transmit force to the packer through a pressure disk (13) and pressure

bars (10), to which rollers (11) are attached to minimize friction against the disk. The bars are fastened to the heads of the clamping bolts using left-hand bolts (12). Around the central passage, a guide skirt (17) is welded to the base of the hermetizer to prevent interference between the housing and the tool joint (3) of the kelly during tripping operations.

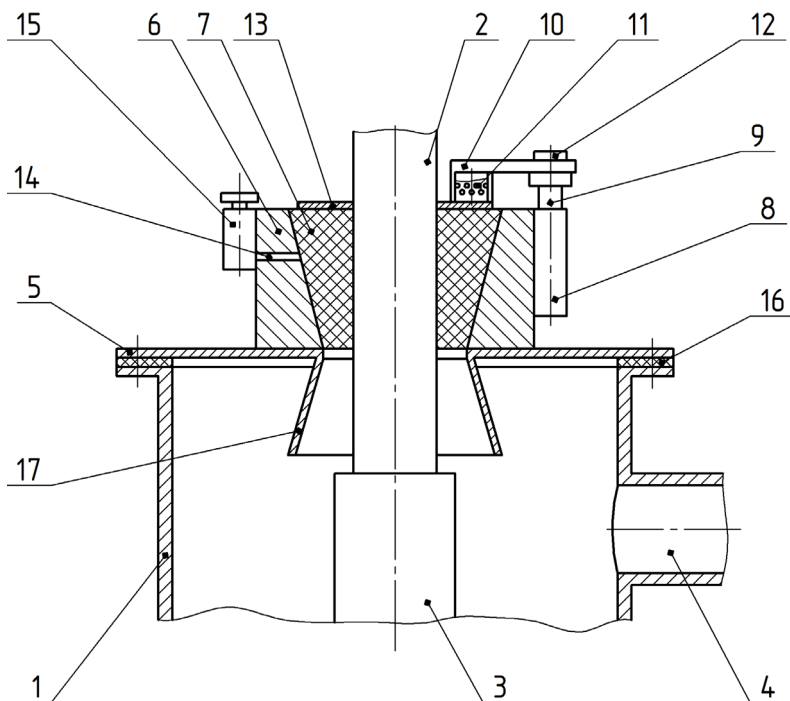

Figure 1 – Wellhead sealing device for drilling large-diameter water wells

1 – conductor casing; 2 – kelly; 3 – tool joint connecting the kelly to the drill string; 4 – inlet pipe; 5 – base plate; 6 – housing; 7 – packer; 8 – threaded bushing; 9 – clamping bolt; 10 – pressure bar; 11 – roller; 12 – left-hand bolt; 13 – pressure disk; 14 – oil supply channel; 15 – lubricator; 16 – sealing gasket; 17 – guide skirt

During drilling, the pump delivers the downward flow of drilling fluid into the well through the inlet pipe (4). Due to the square opening in its center, the packer (7) rotates together with the kelly (2), which moves smoothly downward through the stationary housing of the hermetizer.

The clamping bolts (9), acting through the bars (10), rollers (11), and the rotating pressure disk (13), exert a compressive load on the rubber packer. This load presses the packer tightly against the polished conical surface of the housing (6) and the flat sides of the kelly, thereby eliminating micro-gaps and ensuring sealing integrity.

Wear of the packer is minimal. This is due to the continuous lubrication of its conical surface supplied from the lubricator (15) through the oil channel (14).

In addition, drilling of large-diameter wells is carried out at very low rotational speeds, which further reduces wear and extends packer service life.

Wear on the contact surface between the packer and the kelly is also minimal, since the descent speed of the kelly through the packer usually does not exceed 1 cm/s (which corresponds to a relatively high drilling rate of 36 m/h). In addition, the hermetizer is exposed only to the clean downward flow of water, free of suspended cuttings and solid particles.

Sealing between the base plate (5) and the guide casing (1) is provided by the gasket (16), while the casing itself is cemented in the annulus.

During drill string extension, circulation is stopped, and the string is raised until the kelly tool joint can be placed on the rotary table clamp. Before the upward movement begins, the compressive load on the packer (7) is completely released by loosening the clamping bolts (9), without changing the position of the pressure bars (10). In this state, the kelly can move freely through the packer, while the bars prevent frictional forces from displacing the packer upward from its working position.

As the tool joint (3) approaches the hermetizer, the hoisting operation is stopped. The left-hand bolts (12) are loosened, and the pressure bars are swung aside to clear the packer. When hoisting resumes, the upper end of the tool joint engages the packer and lifts it upward, where it remains positioned above the joint.

After the drill string is set on the rotary clamps, the kelly—with the packer resting on its joint—is unscrewed and moved aside. A new drill pipe section is then connected, the clamps are released, and the string is lowered again until the upper tool joint of the newly added section reaches the proper position. The kelly is then reattached, and drilling resumes. As the kelly's tool joint passes through the hermetizer housing (6), the packer is retained by the conical bore, which guides it back precisely into its working seat.

Before setting the bit back on bottom, the compression system (bolts 9 and 12, bars 10, and rollers 11) is returned to its working configuration to reapply the required sealing force. Lubricant is fed from the lubricator (15) to the friction surfaces. The drilling pump is then started, the bit is lowered to the bottom, and drilling continues.

If bit replacement is required, all operations up to the disconnection and removal of the kelly (2) are identical to those described for drill string extension. The remaining drill pipes are then pulled out; thanks to the guide skirt (17), they pass smoothly through the hermetizer without obstruction.

When the bit approaches the surface, the bolts securing the base plate (5) to the casing (1) are unscrewed. The string is carefully raised so that the bit lifts the base plate and the housing (6) to the required height above the wellhead, after which the wellhead is temporarily sealed with a protective cover.

The worn bit is then unscrewed and replaced with a new one. After removing the cover and lowering the bit below the wellhead, the base plate is reattached to

the top of the casing. The drill string is then lowered back into the well, with the conical bore of the housing serving as a precise guide for the tool joints.

Subsequent operations prior to resuming drilling are identical to those previously described for the drill string extension process.

Let us analyze the distribution of mechanical stresses in the packer material when it comes into contact with the conical bore of the sealing housing. For a simplified theoretical analysis, it is assumed that the total normal force generated by the clamping bolts and transmitted through the disk/bars/rollers is uniformly applied to the conical surface of the packer. The geometric profile of the contact area is represented by a truncated cone with a linearly varying radius along the axial contact length. This formulation makes it possible to derive an analytical dependence of the contact pressure on the radius at a given point of the cone and to obtain an intuitively clear pressure distribution along the contact surface.

Notation and assumptions:

- The total normal force from the bolts F (the sum of the preload forces of all bolts), N. In the calculations $F=50 \text{ kN}=5 \cdot 10^4 \text{ N}$ (a typical working value for a sealing assembly) (Khomenko, et al, 2024);

- Axial length of the conical contact zone $L = 50 \text{ mm} = 0,05 \text{ m}$;

- Radius at the small end of the cone $r_{\min} = 0,225 \text{ m}$; radius at the large end $r_{\max} = 0,275 \text{ m}$; mean radius $r_{\text{mean}} = 0,25 \text{ m}$. These radii are typical for sealing conical packer fits (Pashchenko, et al, 2024);

- The contact surface is considered “thin” along the axis (significant rubber thickness deformation is neglected); the normal force distribution is projected onto the lateral surface area of the cone $dA=2\pi r(x)dx$;

- Additional localization of forces due to surface roughness or deformation is neglected—the problem is intentionally simplified to obtain an analytical expression and a clear qualitative pressure profile.

Analytical formulation of pressure distribution. Let the coordinate $x \in [0, L]$ be defined along the cone axis, where $x = 0$ corresponds to the small radius r_{\min} , and $x=L$ corresponds to the large radius r_{\max} . The radius at any point varies linearly:

$$r(x) = r_{\min} + \frac{r_{\max} - r_{\min}}{L} x. \quad (1)$$

The local contact (normal) pressure is denoted $p(x)$. The equilibrium relation between the total normal force and the pressure integrated over the contact area is given by:

$$F = \int_0^L p(x) 2\pi r(x) dx. \quad (2)$$

Consider a simple functional form of the solution, assuming

$$p(x) = \frac{C}{r(x)}, \quad (3)$$

where C is a constant determined from the equilibrium condition. Substituting into the equation of equilibrium yields:

$$F = 2\pi \int_0^L \frac{\tilde{N}}{r(x)} r(x) dx = 2\pi C \int_0^L dx = 2\pi CL. \quad (4)$$

Hence,

$$C = \frac{F}{2\pi L}. \quad (5)$$

and the analytical expression for the pressure distribution along the axis is

$$p(x) = \frac{F}{2\pi L r(x)}. \quad (6)$$

This expression shows that the local contact pressure is inversely proportional to the local radius of the conical bore: under otherwise identical conditions, the pressure slightly decreases as the radius increases.

Substituting the numerical values:

$$p(x) = \frac{5 \cdot 10^4}{2\pi \cdot 0,05 \cdot r(x)}. \quad (7)$$

The calculations yield a contact pressure range from approximately 579 kPa to 706 kPa, with a mean value of $p_{\text{mean}} \approx 639$ kPa.

The plot of $p(x)$ versus the axial coordinate is shown in Fig. 2 and demonstrates a smooth pressure decrease of about 18–20% from the beginning to the end of the contact zone.

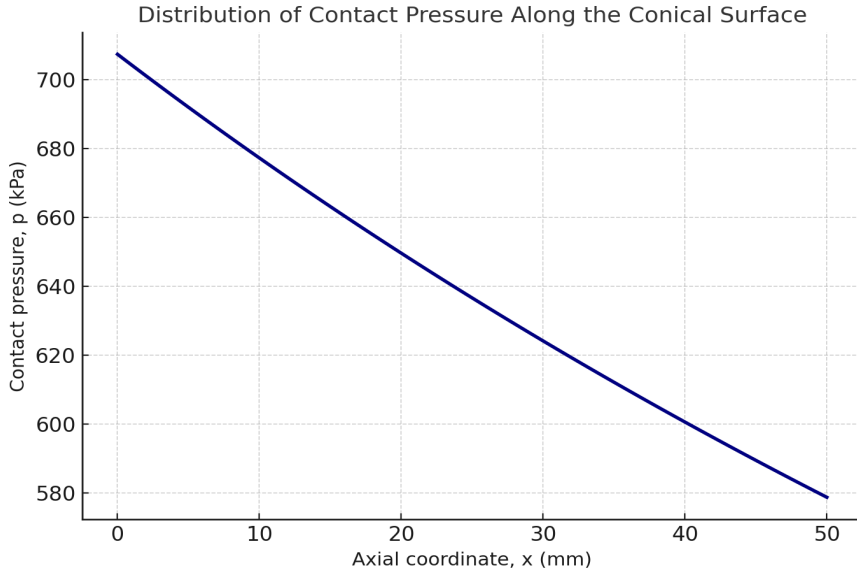

Figure 2 – Distribution of contact pressure along the conical surface

The observed relationship $p(x) \propto 1/r(x)$ indicates that, under otherwise identical conditions, the “narrow” end of the conical bore is subjected to slightly higher contact pressure. From an engineering perspective, this is advantageous: elevated pressure near the small end enhances the tightness of the fit and reduces the likelihood of localized leakage at the upper edge of the seating area, which is typically the point where seal failure begins.

The calculated pressure values (on the order of 0.6–0.7 MPa for the assumed total preload of 50 kN) are significantly lower than the typical limiting pressures permissible for rubber seals in aqueous environments in terms of mechanical compression and long-term durability. Nominal allowable contact pressures for oil-resistant elastomers under static loading generally lie within several megapascals, depending on the compound formulation. This indicates that the selected preload provides a sufficient safety margin without excessive local overcompression of the rubber and without risk of early torsional cracking under static compression.

The pressure distribution along the contact axis is relatively uniform (the difference between the ends is about 128 kPa for the current parameters). Therefore, to further reduce local stresses and achieve a more uniform distribution, it is advisable to increase the axial contact length L (for a given total force F , the pressure will decrease proportionally to $1/L$), or alternatively, to reduce the total preload if adequate sealing can still be maintained at lower pressures.

From the standpoint of wear, since the contact pressure is not highly localized, the rubber rotates together with the mating metal surface, and lubrication is present, the expected rate of abrasive–adhesive wear is limited. Nevertheless, increasing the preload—and consequently the contact pressure—will directly increase the

normal load and, in the presence of relative sliding, the wear rate as well. Thus, the optimal engineering strategy is to select the minimum preload that ensures the required sealing integrity under nominal circulation pressure.

A notable advantage of the conical geometry is that a slight taper converts the axial bolt load into a relatively uniform normal pressure both circumferentially and axially, while also reducing stress concentrations compared with a flat contact interface.

Discussion. The developed wellhead sealing device represents a conceptually new approach to ensuring reliable isolation in the upper interval of large-diameter water wells. Its structural configuration is based on a conical elastomeric packer element combined with a rigid metal supporting shell that transfers axial loads uniformly while preserving radial deformability. Such a design provides an efficient balance between mechanical strength and flexibility, enabling the device to maintain tight contact with the inner surface of the conductor pipe even under varying axial pressures during drilling and casing operations.

The key advantage of the proposed configuration lies in the controlled distribution of contact stresses along the conical interface. Unlike conventional cylindrical or flat-faced seals, which tend to exhibit stress concentration at the edges, the conical geometry allows for a gradual pressure transition from the upper to the lower sections of the sealing surface. As a result, the maximum stresses in the elastomeric body remain within the elastic range, preventing irreversible deformation and ensuring long-term sealing stability. This effect was confirmed by the results of the analytical stress modeling, which demonstrated that the peak values of the equivalent von Mises stress were localized near the midsection of the packer and did not exceed the admissible limits for typical elastomeric materials used in downhole applications.

From a structural standpoint, the sealing unit is particularly effective under low-velocity operational regimes, such as those typical of large-diameter water-well drilling, where the lowering speed of the drill string through the packer is usually below 1 cm/s. Under these conditions, frictional wear is minimal, and the sealing element experiences predominantly static loading. The combination of the tapered geometry and the moderate stiffness gradient across the material volume contributes to self-adjusting behavior under variable compression, which enhances the reliability of the hermetic joint even in the presence of minor surface irregularities or eccentricity of the string.

The proposed design also has important practical advantages related to manufacturability and operational maintenance. The packer assembly can be fabricated using standard molding techniques and easily replaced in the field without disassembling the entire wellhead assembly. The absence of complex moving parts or hydraulic actuators simplifies the installation process and reduces the likelihood of mechanical failure. Moreover, the structural layout allows for compatibility with existing drilling rigs and conductor configurations, making

it suitable for integration into current technological schemes without significant modification.

The theoretical modeling results support the feasibility of the design and its potential for industrial implementation. The calculated stress distribution profiles confirm that the proposed geometry minimizes local overloading and ensures uniform contact pressure over a wide range of deformation states. These findings indicate that the device can sustain multiple sealing and unsealing cycles without significant degradation of performance, which is a crucial factor for field operations involving repeated tool changes or multi-stage well construction.

In summary, the developed sealing system effectively combines simplicity, durability, and adaptability. The conical packer design provides improved sealing reliability and mechanical efficiency compared with traditional flat or cylindrical seals. Analytical evaluation of stress behavior confirms the structural soundness of the concept and its suitability for practical use in large-diameter water wells. The proposed solution therefore represents a significant advancement toward more robust and maintenance-friendly wellhead sealing technologies.

Conclusion. The study's findings lead to the following conclusions:

1. An analytical evaluation of wellhead sealing conditions for large-diameter water wells has been performed, identifying the main structural and operational limitations of existing sealing systems. It has been established that most known designs fail to maintain reliable pressure retention as the diameter increases and are unsuitable for repeated use without complete disassembly.

2. A new wellhead sealing device has been proposed, featuring a conical sealing assembly with adjustable radial expansion of the packer element. This configuration ensures uniform contact pressure distribution along the sealing surface and enhances fixation stability within the large-diameter wellbore.

3. A theoretical stress analysis of the packer body under internal pressure was conducted. The obtained results confirmed that the selected geometry and material provide acceptable equivalent stress levels and maintain shape stability at operating pressures up to 0.8–1.0 MPa.

4. The analysis of contact pressure distribution along the conical surface revealed a smooth decrease from the lower to the upper edge of the packer, indicating uniform compression and the absence of localized overstressed zones.

5. The developed sealing system demonstrates a strong potential for practical implementation in the drilling and operation of large-diameter water wells. Its application can improve wellhead sealing reliability, reduce leakage risks, and provide more stable hydraulic conditions during drilling fluid circulation and casing operations.

References

Bondarenko V., Kovalevska I., Krasnyk V., Chernyak V., Haidai O., Sachko R., & Vivcharenko I. (2024). Methodical principles of experimental-analytical research into the influence of pre-drilled wells on the intensity of gas-dynamic phenomena manifestations. *Mining of Mineral Deposits*, 18(1). – P. 67-81. DOI: 10.33271/mining18.01.067 (in Eng.).

Bourgoyne A.T. (1995). Rotating control head applications increasing. *Oil and Gas Journal*, 93(41). – P. 72–77. (in Eng.).

Davydenko A.N., Kamyshatsky A.F., & Sudakov A.K. (2015). Innovative technology for preparing washing liquid in the course of drilling. *Science and Innovation*, 11(5). – P. 5–13. DOI: 10.15407/scine11.05.005 (in Eng.).

Feng D., Yuan Y., Tan B., Yang C., Xu G., & Wang P.G. (2010). Finite element analysis of the packer rubbers on sealing process. – P. 151-154. DOI: 10.1109/MACE.2010.5535502 (in Eng.).

Hapich H., Zahrytsenko A., Sudakov A., Pavlychenko A., Yurchenko S., Sudakova D., & Chushkina I. (2024). Prospects of alternative water supply for the population of Ukraine during wartime and post-war reconstruction. *International Journal of Environmental Studies*, 81(1). – P. 289-300. DOI: 10.1080/00207233.2023.2296781 (in Eng.).

He Y., Ma H., Tan X., Chen L., Wan J., Yue R., & Yi X. (2025). Mechanical properties and sealing performance evaluation of packers in high temperature underground gas storage. *Scientific Reports*, 15(1). DOI: 10.1038/s41598-025-02496-9 (in Eng.).

Hou Z., Liu Y., Yang G., & Xia J. (2024). Air-lift characteristics of rock core mass in gas-liquid-solid mixed flow. *Physics of Fluids*, 36(4). DOI: 10.1063/5.0200638 (in Eng.).

Hu G., Wang M., Wang G., Zhu T., & Wei L. (2021). Sealing performance and failure mechanism analysis of packing unit used in rotary blowout preventer for under-balanced drilling. *Engineering Failure Analysis*, 129. DOI: 10.1016/j.engfailanal.2021.105654 (in Eng.).

Inhatov A., Haddad J.S., Koroviaka Y., Aziukovskiy O., Rastsvietaiev V., & Dmytruk O. (2023). Study of rational regime and technological parameters of the hydromechanical drilling method. *Archives of Mining Sciences*, 68(2). – P. 285-299. 10.24425/ams.2023.146180 (in Eng.).

Jiang H., Zhao H., Zhang X., Li H., & Xia C. (2025). Design and Performance Study of an Automatic Compensation Wear High-Pressure Rotary Sealing Device. *Chinese Journal of Mechanical Engineering (English Edition)*, 38(1). DOI: 10.1186/s10033-025-01249-z (in Eng.).

Khomenko V., Pashchenko O., Ratov B., Kirin R., Svitlychnyi S., & Moskalenko A. (2024). Optimization of the technology of hoisting operations when drilling oil and gas wells. *IOP Conference Series: Earth and Environmental Science*, 1348(1). DOI: 10.1088/1755-1315/1348/1/012008 (in Eng.).

Kozhevnykov A.O., Dreus A.Yu., Liu B., & Sudakov A.K. (2018). Drilling fluid circulation rate influence on the contact temperature during borehole drilling. *Naukovyi Visnyk Natsionalnoho Hirnychoho Universytetu*, 1. – P. 35-42. DOI: 10.29202/nvngu/2018-1/14 (in Eng.).

Liu Y., Qian L., Xia C., & Yi X. (2022). Design and experimental study on a novel sealing structure of rotary control head for coalbed methane underbalanced drilling. *Engineering Failure Analysis*, 139. DOI: 10.1016/j.engfailanal.2022.106441 (in Eng.).

Pashchenko O., Kamyshatskyi O., Omirzakova E., & Ratova S. (2025). Development and optimization of hard alloy compositions for rock destruction. *Engineering for Rural Development*, 24. – P. 512-518. DOI: 10.22616/ERDev.2025.24.TF110 (in Eng.).

Pashchenko O., Ratov B., Khomenko V., Gusmanova A., & Omirzakova E. (2024). Methodology for optimizing drill bit performance. *International Multidisciplinary Scientific GeoConference Surveying Geology and Mining Ecology Management, SGEM*, 24(1.1). – P. 623-631. DOI: 10.5593/sgem2024/1.1/s06.78 (in Eng.).

Pukish A., Mandryk O., Arkhpyova L., Syrovets S., & Hryniuk D. (2024). Mathematical modeling of pollution of underground aquifers due to mining of minerals. *Mining of Mineral Deposits*, 18(3). – P. 94-103. DOI: 10.33271/mining18.03.094 (in Eng.).

Ratov B., Kuttybayev A., Tileuberdi N., Utepov Z., Aliakbar M., Zhanguirhanova A., Pashchenko O., Kamyshatskyi O., Khomenko V., Zaichuk O., & Seidaliyev A. (2025). Application of Plasticizers Octadecane to Pentatriacontane and Ethylene Glycol in the Manufacture of Metaloceramic Alloys. *ES Materials and Manufacturing*, 28. DOI: 10.30919/mm1563 (in Eng.).

Umirova G., Kuttybayev A., Khomenko V., Muratova S., Biletskiy M., Ratov B., Makhitova Z., Gusmanova A., Tileuberdi N., Sarbopeyeva M., Kamyshatskyi O., & Zhang L. (2025). Advanced

Approaches to Depth Optimization in Large-Diameter Water Well Drilling in Mangystau Peninsula. *Engineered Science*, 36, 1605. DOI: 10.30919/es1605 (in Eng.).

Vytyaz O., Chernova O., Stavychnyi Y., Martyniuk R., & Ziaja J. (2024). Increasing the reliability of oil and gas well fastening with polycomponent plugging systems. *Mining of Mineral Deposits*, 18(3). – P. 82-93. DOI: 10.33271/mining18.03.082 (in Eng.).

Wu J., He Y., Wu K., Dai M., & Xia C. (2021). The performance optimization of the stripper rubber for the rotating blowout preventer based on experiments and simulation. *Journal of Petroleum Science and Engineering*, 204, 108623. DOI: 10.1016/J.PETROL.2021.108623 (in Eng.).

Publication Ethics and Publication Malpractice in the journals of the Central Asian Academic Research Center LLP

For information on Ethics in publishing and Ethical guidelines for journal publication see <http://www.elsevier.com/publishingethics> and <http://www.elsevier.com/journal-authors/ethics>.

Submission of an article to the journals of the Central Asian Academic Research Center LLP implies that the described work has not been published previously (except in the form of an abstract or as part of a published lecture or academic thesis or as an electronic preprint, see <http://www.elsevier.com/postingpolicy>), that it is not under consideration for publication elsewhere, that its publication is approved by all authors and tacitly or explicitly by the responsible authorities where the work was carried out, and that, if accepted, it will not be published elsewhere in the same form, in English or in any other language, including electronically without the written consent of the copyright-holder. In particular, translations into English of papers already published in another language are not accepted.

No other forms of scientific misconduct are allowed, such as plagiarism, falsification, fraudulent data, incorrect interpretation of other works, incorrect citations, etc. The Central Asian Academic Research Center LLP follows the Code of Conduct of the Committee on Publication Ethics (COPE), and follows the COPE Flowcharts for Resolving Cases of Suspected Misconduct (http://publicationethics.org/files/u2/New_Code.pdf). To verify originality, your article may be checked by the Cross Check originality detection service <http://www.elsevier.com/editors/plagdetect>.

The authors are obliged to participate in peer review process and be ready to provide corrections, clarifications, retractions and apologies when needed. All authors of a paper should have significantly contributed to the research.

The reviewers should provide objective judgments and should point out relevant published works which are not yet cited. Reviewed articles should be treated confidentially. The reviewers will be chosen in such a way that there is no conflict of interests with respect to the research, the authors and/ or the research funders.

The editors have complete responsibility and authority to reject or accept a paper, and they will only accept a paper when reasonably certain. They will preserve anonymity of reviewers and promote publication of corrections, clarifications, retractions and apologies when needed. The acceptance of a paper automatically implies the copyright transfer to the Central Asian Academic Research Center LLP.

The Editorial Board of the Central Asian Academic Research Center LLP will monitor and safeguard publishing ethics.

Requirements for articles design for publication in the journal are available on the websites:

**[www:nauka-nanrk.kz](http://www.nauka-nanrk.kz)
<http://www.geolog-technical.kz/index.php/en/>
ISSN 2518-170X (Online),
ISSN 2224-5278 (Print)**

Managing Editor: *T. Apendiev*
Editors: *D.S. Alenov, A.Shormakova*
Computer layout: *G.D. Zhadyranova*

Signed for print: April 10, 2026
Format: 70×90 1/16. 26.5 printed sheets. Order No. 2.